

Kambrook - Australia

Building 2, Port Air Industrial Estate

1A Hale Street

Botany NSW 2019

Australia

Customer Service Line 1300 139 798

Customer Service Fax 1800 621 337

www.kambrook.com.au

Kambrook - New Zealand

Private Bag 94411

Botany, Manukau

Auckland 2163

New Zealand

Customer Service Line/

Spare Parts 0800 273 845

Customer Service Fax 0800 288 513

www.kambrook.co.nz

KAMBROOK

THE SMARTER CHOICE



Essentials
550W
Direct Drive

KFP400

Instruction Booklet

Important

Please retain your instruction book for future use.

In the event that you need some assistance with your Kambrook appliance, please contact our Customer Service Department on 1300 139 798 (Australia) or 09 271 3980 (New Zealand). Alternatively, visit us on our website at www.kambrook.com.au

Contents

Kambrook Recommends Safety First	p4
Your Kambrook Essentials 550W Food Processor	p7
Assembly and Operation of Your Food Processor	p8
Blade Operating Guide	p12
Maintaining, Cleaning and Storage for Your Kambrook Food Processor	p16
Recipes	p17

IMPORTANT: Please retain your instruction book for future use.

At Kambrook, we believe that safe performance is the first priority in any consumer product, so that you, our valued customer can confidently use and trust our products. We ask that any electrical appliance that you use be operated in a sensible fashion with due care and attention placed on the following important operating instructions.

Important Safeguards For Your Kambrook Food Processor

- Carefully read all instructions before operating the Kambrook Food Processor for the first time and save for future reference.
- Remove and safely discard any packaging material and promotional labels before using the Food Processor for the first time.
- To eliminate a choking hazard for young children, remove and safely discard the protective cover fitted to the power plug of this appliance.
- Do not place the Food Processor near the edge of a bench or table during operation. Ensure the surface is level, clean and free of water and other substances.
- Do not use the Food Processor on a sink drain board.
- Do not place the Food Processor on or near a hot gas or electric burner, or where it could touch a heated oven.
- Handle the Food Processor and attachments with care – remember the blades and discs are razor-sharp and should be kept out of the reach of children.
- Use the blade protector when storing the processing blade.
- Always ensure the Food Processor is completely assembled before operating. The appliance will not operate unless properly assembled.
- Ensure the control switch button is in the 'OFF' position and the Food Processor is switched off at the power outlet and the power cord is unplugged before attaching the processing blade, reversible disc or processor lid.
- Always secure the processor bowl onto the motor base before attaching the processing blade or reversible disc.
- Ensure the processor lid is securely locked in place before operating.
- Do not remove the processor bowl from the motor base whilst in operation.
- Do not push food into the feed chute with your fingers or other utensils. Always use the food pusher provided.
- Keep fingers, hands, knives and other utensils away from moving blades and discs.

- Do not place hands or fingers into the processor bowl of the Food Processor unless the motor, processing blade and reversible disc have come to a complete stop. Ensure the control switch button is in the 'OFF' position and the appliance is switched off at the power outlet and the power cord is unplugged before removing the lid from the Food Processor bowl.
- Ensure the motor and processing blade or reversible disc have completely stopped before disassembling. Ensure the control switch button is in the 'OFF' position and the appliance is switched off at the power outlet and the power cord is unplugged from the power outlet before attempting to move the appliance, when not in use, if left unattended and before disassembling, cleaning or storing.
- Do not use attachments other than those provided with the Food Processor.
- Do not attempt to operate the Food Processor by any method other than those described in this booklet.
- Care should be taken when removing the food from the processing bowl by ensuring the motor and the processing blade or reversible disc, have completely stopped before disassembling. Ensure the control button is in the 'OFF' position, the appliance is switched off at the power outlet and unplugged, before removing the lid from the bowl. The processor bowl should then be unlocked from the motor body and the processor blade or reversible disc carefully removed before attempting to remove the processed food.
- Do not blend a dry, thick or heavy mixture for more than 60 seconds without turning the Food Processor off and stirring the ingredients before continuing to blend.
- If the Food Processor is operated continuously for too long, it should be allowed to rest for 25–30 minutes before recommencing.
- Do not process hot or boiling liquids – allow liquids to cool before placing into the processing bowl.
- Do not move the Food Processor whilst in operation.
- Do not leave the Food Processor unattended when in use.
- Do not place any part of the Food Processor in the microwave oven.
- Do not process thin fluids such as water, milk, stock, juice, etc., above MAX LIQUID FILL level marked on the processor bowl as this could result in overflow. To reduce the risk of overflow, always add drier or thicker ingredients to the processor bowl prior to adding fluids.
- Do not place anything on top of the Food Processor when the lid is on, when in use and when stored.
- Keep the Food Processor clean. Follow the Maintaining Your Food Processor instructions provided in this book.

Important Safeguards For All Electrical Appliances

- Fully unwind the power cord before use.
 - Connect only to 230V or 240V power outlet.
 - Do not let the power cord hang over the edge of a bench or table, touch hot surfaces or become knotted.
 - To protect against electric shock, do not immerse the power cord, power plug or appliance in water or any other liquid, unless it is recommended in the cleaning instructions.
 - The appliance is not intended for use by persons (including children) with reduced physical, sensory or mental capabilities, or lack of experience and knowledge, unless they have been given supervision or instruction concerning use of the appliance, by a person responsible for their safety.
 - Children should be supervised to ensure that they do not play with the appliance.
 - It is recommended to inspect the appliance regularly. Do not use the appliance if the power supply cord, plug, connector or appliance becomes damaged in anyway. Return the entire appliance to the nearest authorised Kambrook Service Centre for examination and/or repair.
 - Any maintenance other than cleaning should be performed at an authorised Kambrook Service Centre.
 - This appliance is for household use only. Do not use this appliance for other than its intended use. Do not use in moving vehicles or boats. Do not use outdoors.
- Misuse may cause injury.**
- The installation of a residual current device (safety switch) is recommended to provide additional safety protection when using electrical appliances. It is advisable that a safety switch with a rated residual operating current not exceeding 30mA be installed in the electrical circuit supplying the appliance. See your electrician for professional advice.
 - Always turn the appliance to the OFF position, switch off at the power outlet and unplug at the power outlet when the appliance is not in use.
 - Before cleaning, always turn the appliance to the OFF position, switch off at the power outlet, unplug at the power outlet and remove the power cord, if detachable, from the appliance and allow all parts to cool.
 - Do not place this appliance on or near a heat source, such as hot plate, oven or heaters.
 - Position the appliance at a minimum distance of 20cm away from walls, curtains and other heat or steam sensitive materials and provide adequate space above and on all sides for air circulation.



CAUTION: The processing blade and reversible disc are extremely sharp, handle with care at all times. Do not place hands, knives, or other utensils into the feed chute. Always use the food pusher to push the food down the feed chute.

Your Kambrook Essentials 550W Food Processor

1. Control Switch – with 'OFF', single speed 'ON' function plus 'PULSE' function for fast and simple processing control
2. Motor - 550 watts of processing power
3. Processor bowl - extra large 1.5 litre capacity for slicing or shredding vegetables, processing foods, mixing doughs etc.
4. Drive shaft – fits either the processing blade or the reversible disc
5. Food pusher and removable inner 150ml measuring cup – fits into the feed chute for safe adding of foods onto the processor bowl.
6. Processor lid and feed chute
7. Stainless steel reversible disc – for slicing or shredding
8. Stainless steel processing blade – for all chopping, mixing and processing tasks
9. Non-skid suction feet – for added stability
10. Processing blade protective cover – for storing processing blade when blade is not in use (not shown)



Assembly & Operation of Your Food Processor

Before First Use

Before first use remove and safely discard any promotional labels and wash the food processor bowl, processor lid, processing blade and reversible disc in warm, soapy water. Dry thoroughly.



CAUTION: Blades and discs must be handled carefully as they are sharp. Place the motor base on a level, flat surface.

The food processor features 2 safety locking devices.

NOTE: The food processor will not work unless all of the below directions have been followed.

1. The processor bowl is correctly aligned and in position (see Fig.1)

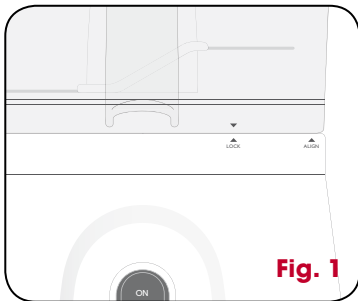

2. The processor lid is correctly aligned and locked into place (see Fig.2, Fig.4)

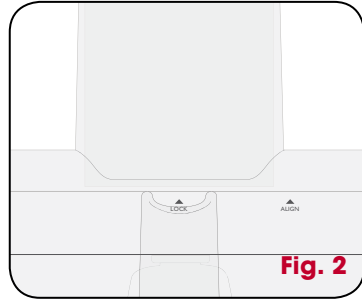

NOTE: Always ensure that the food processor is disconnected from the power outlet before assembling or disassembling the food processor.

Correct Placement of the Processor Bowl

1. Place the motor base on a flat, dry surface such as a bench top. Make sure that the motor base is turned off at the power outlet and the power cord is unplugged.
2. Place the empty processor bowl onto motor base, with the handle on the right, align the "▼" symbol on the processor bowl with the "▲" symbol on the motor base.
3. Turn the bowl clockwise until the "▼" symbol on the processor bowl is aligned with the 'lock' indicator symbol "▲" on the motor base.



WARNING: All blades must be handled carefully as they are sharp.

Using the Processing Blade

1. Carefully remove the protective cover from the processing blade.
2. Hold the central plastic spindle of the processing blade and carefully place it over the drive shaft (see Fig. 3).

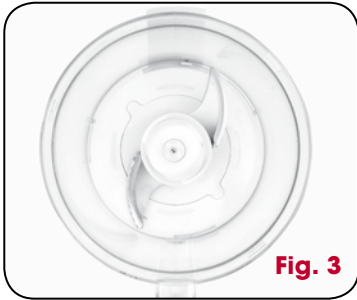

Fig. 3

3. Place the processor lid on top of the processor bowl and lock into place (see Fig. 4).

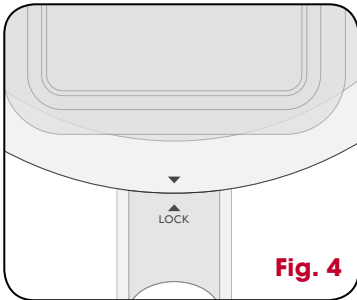

Fig. 4

4. Plug the power cord into the power outlet and switch the power outlet 'On'.

5. To begin operation, press the control switch button to either the 'ON' or 'PULSE' position, depending on your requirements. For short bursts of power, use the 'PULSE' setting.
6. To remove the processing blade, hold the central plastic spindle to pick up the processing blade.

Using the Reversible Processing Disc

The stainless steel reversible disc has different processing blades on each side. The reversible disc has a slicing function on one side and a shredding function on the other side.

1. Place the reversible disc on the drive shaft with the selected blade facing upwards (see Fig. 5).



Fig. 5

NOTE: The corresponding name of the SLICE or SHRED is marked on each side of the reversible disc.

2. To remove the reversible disc, hold the central plastic spindle on the reversible disc to pick up the reversible blade.

NOTE: Ensure that the unit is in the 'OFF' position, and switched off and unplugged at the power outlet before using the reverse side of the reversible disc, or changing to the processing blade.



WARNING: The processing blade and reversible disc must be handled carefully as they are sharp!

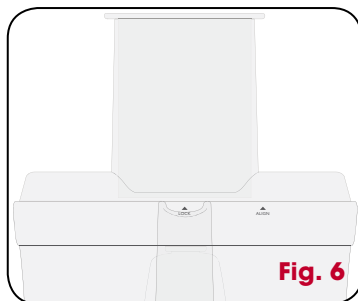

NOTE: The food processor will not operate unless the processor bowl and processor lid are correctly locked into position.

Correct Placement of the Processor Lid

1. Place the processor lid on top of the processor bowl, align the "▼" symbol on the processor lid with the "▲" symbol on the upper side of the processor bowl.
2. Turn the processor lid clockwise – until the "▼" symbol on the processor lid is aligned with the "▲" symbol on the processor bowl handle. A "click" sound will be heard, to indicate it is correctly locked (see Fig. 6).

Operating the Food Processor

1. Ensure the control switch is in the 'OFF' position.
2. Insert power plug into a 230V or 240V power outlet and turn the power outlet on.
3. The food processor is now ready to be operated. To begin operation, press the control switch from the 'OFF' position to either the 'ON' or 'PULSE' position, depending on your requirements. For short bursts of power, switch to the 'PULSE' setting.

For slicing and shredding – ensure that the food items you want to slice or shred are of a suitable size to be fed through the feed chute.

Place the food inside the feed chute and push down with the food pusher.

NOTE: Never push down any foods with your hands and do not put your hands down the feed chute at any time during processing. Always use the food pusher to push the food down the feed chute.

For using the processing blade – with the ingredients inside the processor bowl, start the unit using the 'ON' or 'PULSE' setting. Before commencing ensure that the food pusher is in place to avoid splashing from the feed chute. Ingredients can be added through the feed chute whilst processing.

If ingredients stick to the sides of the processor bowl during processing, press the control switch button to the 'OFF' position, switch off at the power outlet and unplug, remove the processor lid and then push the food back onto the blades using the plastic spatula to scrape down the sides of the bowl. Then recommence processing.

NOTE: Do not over fill the processor bowl above the 'MAX LEVEL' line for solids and above the 'MAX LIQUID FILL' mark for liquids as this could result in overflow. To reduce the risk of overflow, always add drier or thicker ingredients to the processor bowl prior to adding fluids.

NOTE: The food processor is designed so the motor will not operate without the processor bowl and lid correctly locked into position. In the event that the food processor starts without the processor bowl and lid correctly locked into position, immediately disconnect at the power outlet and return to your local Kambrook Service Centre for examination.

Blade Operating Guide

The Stainless Steel Processing Blade

The cutting edge of this blade is extremely sharp, it should only ever be held by the central plastic spindle.

ALWAYS store the blade with the protective cover provided.

Chopping	Use Processing Blade
Ingredients	Procedure
Onions, Vegetables, Fruits and Cooked Meats	Cut ingredients into approximately 2.5cm cubes. Place in processor bowl, up to 750g at a time. Process, using the 'PULSE' setting until the ingredients are chopped as desired. Remove lid and scrape the sides down with the spatula between pulses to ensure more even chopping.
Raw Meats (Boneless)	Trim the meat of fat and gristle, remove any bones. Cut into 2.5cm cubes. Process up to 750g at a time, scraping down the sides of the processor bowl, until the meat is coarse or fine as desired.
Herbs	Make sure the herbs are as dry as possible. Place in the processor bowl and process until finely chopped. Scrape down the sides of the processor bowl at least once during processing. Up to 4 cups of firmly packed herbs can be processed at a time.
Breadcrumbs or Biscuit	Quarter the slices of bread and break up the biscuits. Place them in the processor bowl. Process up to 1½ loaves of bread, crusts removed, or 1 loaf with crusts, at a time. Use stale bread for dry breadcrumbs.
Nuts (Shells Removed)	Place up to 2 cups of nuts in the processor bowl at a time and process using the 'PULSE' setting. If chopped too finely the nuts will become oily and eventually form a butter. Processing smaller quantities at one time will ensure even chopping.
Hard Cheeses	To process hard cheese such as Parmesan, first cut the cheese into 2cm cubes. Drop cubes of cheese down the feed chute, processing 200g at a time.
Hard Boiled Eggs	Shell and halve the eggs before placing in the processor bowl. Process using the 'PULSE' setting.

NOTE: When mixing liquids with the processing blade, do not fill above the bowls 750ml fill line. Do not use the MAX speed as liquids will spill over the bowl.

Pureeing	Use Processing Blade
Ingredients	Procedure
Cooked Soups, Sauces (1 Litre or less)	Place up to 4 cups of mixture in the processor bowl and process, until desired consistency is reached.
Dips, Spreads	Place ingredients in the processor bowl and process. If some ingredients are to remain in pieces, add them last and mix in using the 'PULSE' setting.
Cooked Vegetables, Fruit	These may first be cooked in a saucepan. Process until desired consistency is reached.

Mixing	Use Processing Blade
Ingredients	Procedure
Yeast Dough	Add ingredients in the order listed in the recipe. Add liquids through the feed chute with the motor turning.

The Stainless Steel Reversible Disc

Slicing	Use Reversible Disc – Slice
Ingredients	Procedure
Onions	Peel the onions and halve if too large to fit into the feed chute. Place the onions in the feed chute, cut edge down. Process, exerting firm pressure on the food pusher.
Carrots, Zucchini, Eggplant and Bananas	Prepare the foods in the usual way. For rounds arrange foods vertically in the feed chute, cutting them so they are even in height. For slices arrange foods horizontally in the feed chute. Process using firm pressure on the food pusher.
Capsicums	Remove the core and seeds. Halve the capsicums if necessary and arrange them vertically in the feed chute. Process using firm pressure on the food pusher.
Mushrooms	Wipe the mushrooms and pack in the feed chute on their sides. Process using firm pressure on the food pusher.
Apples and Peaches	Peel if desired, remove the stone and quarter the fruit. Lie the quarters on their sides in the feed chute and process using firm pressure on the food pusher.
Beans	Prepare the beans. Cut into lengths and pack horizontally into the feed chute. Process using firm pressure on the food pusher.
Cheese	Cut the cheese into pieces small enough to just fit the feed chute. Process using light pressure on the food pusher to prevent cheese crumbling.
Cabbage	Cut cabbage into wedges to fit feed chute and process using firm pressure on the food pusher.
Lettuce	Separate the leaves of the lettuce and wash and dry. Roll the leaves firmly and pack into the feed chute. Process using firm pressure on the food pusher.
Raw Meat, Fish and Chicken	Trim meat of fat and gristle and cut to fit snugly in the feed chute. Freeze until partly frozen. Process using firm pressure on the food pusher.
Cooked Meats, Cabanossi and Salami	Pack the feed chute snugly placing meat in the feed chute vertically. Process using firm pressure on the food pusher. For more even slicing remove sausage skins first.
Cucumbers	Trim the ends of the cucumber and cut into lengths to fit the feed chute vertically. If the cucumber is too wide, scoring it length wise with a fork will make it more pliable. Process using firm pressure on the food pusher.
Potatoes	Peel the potatoes and cut into pieces if necessary to fit the feed chute. Process using firm pressure on the food pusher.

Blade Operating Guide *continued*

The Stainless Steel Reversible Disc

Shredding	Use Reversible Disc – Shred
Ingredients	Procedure
Onions and Potatoes	Pack into the feed chute and process using firm pressure on the food pusher. Peel and cut into pieces if necessary to fit the feed chute.
Carrots, Zucchini and Cucumber	Prepare the vegetables and pack into the feed chute. Packing vertically will give shorter shreds than packing horizontally. Process using firm pressure on the food pusher.
Cheese	Cut the cheese to fit the feed chute snugly. Process using a light pressure on the food pusher to prevent the cheese crumbling.
Chocolate	Break chocolate into pieces to fit the feed chute and process using firm pressure on the food pusher.
Onions	Peel the onions and chop into halves. Place onions in the feed chute, cut edge down. Process using firm pressure on the food pusher.
Garlic and Ginger	Peel and place minimum 250g into the feed chute and process using firm pressure on the food pusher. Note: If small quantities are used, they may block the holes in the shredding disc. To help wash the ingredients through, pour ¼ cup olive oil (for garlic) or ¼ cup sherry (for ginger) down feed chute. Excess amount can be stored for later use.

Maintaining, Cleaning and Storage for Your Kambrook Food Processor

1. Always switch the food processor off at the power outlet and then unplug before disassembling any parts.
2. Wash the processor lid, processor bowl, reversible disc, food pusher, and processing blades in warm soapy water after each use. Rinse thoroughly and dry.
3. Do not allow the processing blade and the reversible disc to soak in water for an extended period of time, as they may damage the metal finish.
4. The processing blade and reversible disc are extremely sharp! Handle with care. They should only be held by the central plastic spindle. Use caution when handling and storing these parts. Always store the processing blade with the protective cover provided and out of reach from children.
5. Never use an abrasive cleaner. The processing blade, processor lid, processor bowl, reversible disc and food pusher may also be washed in the dishwasher.
6. Wipe the motor housing with a soft, damp cloth (do not use abrasive agents or cloths which can damage the surface). Dry and polish with a soft, lint free cloth.
7. DO NOT immerse the motor base, power plug or cord in water or any other liquid.
8. Before storage, thoroughly wash and dry all removable parts. Assemble the food processor and store on the kitchen bench or in an easy to access cupboard. Store out of reach of children. Store the appliance upright. Do not store anything on top of the appliance.

Recipes

Recipes

Kambrook Dukkah

Makes 8 serves

- 1 teaspoon coriander seeds
- 1 teaspoon cumin seeds
- ½ teaspoon cinnamon, ground
- 2 teaspoon sesame seeds
- 1 tablespoon hazelnuts
- 1 tablespoon almonds
- 1 teaspoon sea salt

1. Using the processing blade, place all ingredients into the processing bowl and lock the lid into the sealed position with the pusher inserted.
2. Pulse until mixture is consistent and combined.
3. Serve with crusty bread dunked in good quality olive oil.

Olive Tapenade

Makes 8 serves

- 3 tablespoons kalamata olives, pitted
- 4 teaspoons olive oil
- 2 cloves garlic
- 1 teaspoon rock salt
- 1 teaspoon lemon juice
- 8 basil leaves

1. Using the processing blade, place all ingredients into the processing bowl and lock the lid into the sealed position with the pusher inserted.
2. Pulse until mixture is consistent and combined.
3. Serve with crusty bread.

Satay Sauce

Makes 8 serves

3 tablespoons peanuts
2 tablespoons coconut cream
1 small red chilli, chopped
2 cloves garlic, chopped
4 teaspoons kecap manis
2 teaspoons lime juice

1. Using the processing blade, place all ingredients into the processing bowl and lock the lid into the sealed position with the pusher inserted.
2. Pulse until mixture is consistent and combined.
3. Serve over chicken skewers or on vegetable burgers.

Basil and Cashew Dip

Makes 8 serves

2 tablespoons basil leaves, chopped
2 teaspoons olive oil
1 tablespoon cashew nuts
1 teaspoon rock salt
2 teaspoons lemon juice
1 clove garlic
2 teaspoons parmesan cheese, grated

1. Using the processing blade, place all ingredients into the processing bowl and lock the lid into the sealed position with the pusher inserted.
2. Pulse until mixture is consistent and combined.
3. Serve with biscuits, vegetable batons or bread.

Potato and Leek Soup

Makes 6 serves

1 small brown onion, peeled, diced
1 leek, thinly sliced, washed thoroughly
600g potatoes, peeled, diced
50g butter
1 tablespoon olive oil
1 clove garlic, peeled, minced
2 sprigs thyme, shredded
600ml vegetable stock
150ml pure cream

1. Using the slicing side of the reversible disc on the food processor, lock the lid into place and push the onion, leeks and potatoes down the feed chute with the food pusher, until all have been thinly sliced.
2. In a saucepan, heat the butter and oil. Add the garlic, onion and leek and sauté until golden brown.
3. Place the potatoes, onion mix and thyme into a 3 litre pot and pour over stock. Place a lid onto the pot and simmer over a low heat for 25 minutes. Allow to cool for 10 minutes.
4. Using the processing blade, pour the soup and cream into the food processor, in two batches and process for 30 seconds or until desired consistency is reached.
5. Serve soup with fresh bread.

French Onion Soup

Makes 6 serves

4 large onions (about 1kg)
50g butter
1 teaspoon olive oil
1 tablespoon brown sugar
50ml brandy
750ml vegetable stock
1 tablespoon balsamic vinegar
2 bay leaves
2 thyme sprigs

1. Using the slicing side of the reversible disc on the food processor, lock the lid into place and push the onions down the feed chute, with the food pusher until all onions have been thinly sliced.
2. In a 2 litre saucepan, heat the butter and oil over a medium heat and add the onion. Sauté until golden brown.
3. Add the brown sugar and brandy and cook off for 5 minutes.
4. Add the stock, balsamic, bay leaves and thyme and simmer over a low heat for 30 minutes.
5. Serve soup with fresh bread, toasted with cheese.

Leek and Three Cheese Potato Bake

Serves 8

- 2 medium leeks, washed
- 1500g potatoes, peeled
- 1 tablespoon olive oil
- 40g butter
- 3 sprigs lemon thyme, shredded
- 1 cup pure cream
- ½ cup milk
- ½ cup low fat ricotta cheese
- 50g packet French onion soup mix
- ½ cup parmesan cheese, grated
- ½ cup vintage cheddar cheese, grated

1. Preheat a fan forced oven to 180C.
2. Using the slicing side of the reversible disc on the food processor, lock the lid into place and push the leeks down the feed chute with the food pusher, until the whole leek has been thinly sliced, wash thoroughly.
3. Using the slicing side of the reversible disc on the food processor again, place the potatoes down the feed chute until all potatoes have been thinly sliced.
4. Using a frypan, over a medium heat, heat the oil and butter and then sauté the leek until golden brown, about 6 minutes.
5. Layer a 1/3 of the potato slices on the base of a 3 litre crockery dish and then add 1/3 of the leek, repeat until three layers have formed.
6. In a 1 litre jug, whisk together the thyme, cream, milk, ricotta and soup mix. Pour over the potato and leek.
7. Top with parmesan and cheddar cheeses and bake for 45 minutes.
8. Serve over baby spinach or as an accompaniment to another meal.

Sausage Rolls

Makes 4 sausage rolls

- 500g sausage mince
- 1 small onion, peeled, diced
- 1 clove garlic, peeled, minced
- 5 slices of bread, crumbed
- 2 tablespoons tomato paste
- 1 tablespoon sweet chilli sauce
- 2 x 59g free-range eggs
- 2 sheets puff pastry
- 1 tablespoon milk
- 1 tablespoon sesame seeds

1. Preheat a fan forced oven to 180°C.
2. Using the processing blade, place the mince, onion, garlic, bread, tomato paste, chilli and eggs into the processing bowl and lock the lid into place. Pulse until mixture is consistent and combined, about 20 seconds.
3. Slice puff pastry sheets in half and place a thick line of mince mixture onto each piece, lengthways. Fold pastry over and seal by gently pushing the pastry together where it overlaps.
4. With a pastry brush, brush the tops with milk and top with sesame seeds.
5. Bake for 30 minutes and serve with tomato chutney.

Cheese and Bacon BBQ rolls

Makes 6 rolls

300ml warm water
40ml olive oil
1 teaspoon sugar
1 teaspoon salt
500g bread flour
2 teaspoons yeast
3 tablespoons bbq sauce
1 cup bacon, diced
1 cup tasty cheese, **grated**

1. Place water, olive oil, sugar, salt, flour and yeast into food processor bowl with processing blade and pulse for about 40 seconds. Shape into a ball and place in a large clean glass bowl. Brush with a little water, using a pastry brush and cover with a damp tea towel. Place in a warm, draught-free place to prove for 1½ hours or until doubled in size.
2. Preheat a fan forced oven to 180°C.
3. Place dough ball back into food processor bowl and pulse using the processing blade for a further 1 minute. Roll dough ball out onto a floured surface and cut into 6 balls.
4. Place the 6 dough balls onto a baking tray lined with baking paper. Top each evenly with bbq sauce, bacon and cheese.
5. Place into the oven and bake for 20 minutes.

Beef Casserole with Wholemeal Parmesan Dumplings

500g wholemeal plain flour
300ml water
5 tablespoons olive oil
2 teaspoons dry yeast
1 teaspoon caster sugar
4 cloves garlic, peeled, minced
2 brown onions, peeled, halved
1 tablespoon worcestershire sauce
2 tablespoons plain flour
1kg blade steak, diced
250ml beef stock
1 **tablespoon tomato paste**
2 **teaspoons fresh oregano**
500g chat potatoes, halved
1 **cup parmesan cheese, grated**

1. Using the processing blade on the food processor, add the flour, water, 2 tablespoons of oil, yeast and sugar to the processing bowl and lock the lid into place. Pulse for 1 minute or until the dough reaches a smooth ball. Place into a clean glass bowl and cover with plastic wrap. Place in a warm place and allow to stand for 1 hour.
2. Using the slicing side of the reversible disc on the food processor, lock the lid into place and push the onion down the feed chute with the food pusher, until all have been thinly sliced.
3. In a 3 litre pot, heat the oil over a medium heat on the stovetop and saute the onions and garlic. Add the worcestershire, flour and beef and continue to sauté until golden brown.
4. Stir through the stock, tomato, oregano and potatoes and allow to simmer over a low heat for 45 minutes.
5. Preheat a fan forced oven to 180°C.
6. Place the stew into a 3 litre oven safe crockery bowl. Separate the dough ball into 12 smaller dough balls and place evenly over the top of the stew. Sprinkle with cheese and bake for 30 minutes.

